



**New approach to  
sprinkler systems**



---

## CONVENTIONAL SPRINKLER SYSTEMS

Basic principles of sprinkler fire suppression have not been changed for more than a century since first sprinklers were introduced into practice. At the same time, efficient means of fast fire detection, as well as opportunities of programming algorithms of any complexity for operation of fire suppression systems have been developed. Based on the analysis of the limitations inherent in conventional water-based fire suppression systems, the following avenues and requirements for improvements were identified:

- To reduce damage from the fire, fire suppression system must be activated at the early stage of fire growth (implementation of this requirement will increase false alarm probability);
- To reduce damage from spilled water, the wetted area must be bounded by the fire size at time instant of system activation;
- There must be an option of quick termination of water supply after fire suppression is complete or in case if false alarm is confirmed;
- There must be an option of displaying the information on activated sprinklers and the operation of the entire system for remote control by an operator.

Neither usual sprinkler system nor deluge one simultaneously fit all the above principles. So a new approach to sprinkler systems has been designed, manufactured, properly reflected in fire codes and brought to the market.

Traditional sprinkler technology was improved by using modern technical solutions. For this purpose design of sprinklers was changed and special systems for managing such sprinklers were developed.

## NEW APPROACH TO SPRINKLER SYSTEMS

### ELECTRICAL ACTIVATION

The first new option introduced in conventional sprinkler is an opportunity to enforce its activation by electric signal. The option of controlled sprinkler activation was implemented in the starting device, which consists of the heating element placed on the glass bulb. Being switched on by the external signal, the element warms the bulb up to the break-up temperature.

### MONITORING OF SPRINKLERS

The second improvement introduced in this work is a facility to monitor the activation of the sprinkler. Such a facility consists of the interrupting contact placed between the bulb and the lock valve. The contact is closed when the sprinkler is inactive and it disconnects when the sprinkler activates. Availability of the check-up facility is crucial for getting information of sprinkler status. It may be used when we need information about precise location of fire.

However, the problem of late fire detection still remains. But a serious step forward was made: fast fire detection and sprinkler activation were combined.

### INTERACTION WITH FIRE DETECTORS

Electrically activated sprinklers with low-inertia fire detectors were integrated. The detector is located near the sprinkler. It observes the same zone as the sprinkler and works as an accelerator. When it initiates a fire alarm the nearest sprinkler activates. In Russian standards such fire detector is named the satellite. In practice, sprinklers with two types of satellite detectors were integrated: the first one responds to the temperature growth rate in the fire-driven flow. The second one responds to flame radiation and practically has no inertia. First variant is preferable because of the lower cost of heat detectors. The delay of activation comparing with the flame detector is quite acceptable in most cases.

Usage of two different principles of fire detection simultaneously makes it possible to considerably reduce a possibility of false activation.

## ALGORITHM OF SPRINKLER ACTIVATION

Three scenarios of implementation of sprinklers with electrical activation were explored: individual activation or group activation – dynamic and static.

### INDIVIDUAL ACTIVATION OR SPRINKLERS WITH ACCELERATOR.

In this kind of a fire suppression system, electrically activated sprinklers are integrated with the differential temperature sensors as described above.

#### Advantages of this solution:

- This design solution makes the time period between ignition and sprinkler activation several times less than that in traditional systems (this design is therefore referred as thermally accelerated).

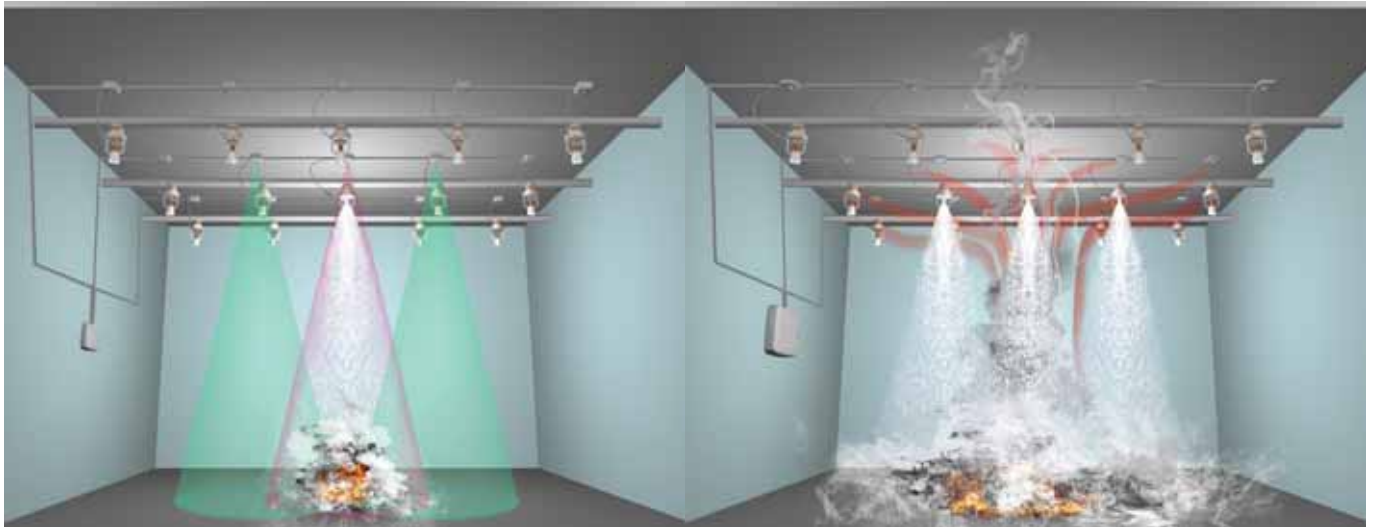

with flame detector

with heat detector

- The lower calorific power of a fire source at the moment of activation allows reducing the amount of water required for fire extinguishing. In many cases it is a very important advantage. Also it helps to decrease the size of pipes, the power of pumps and the volume of reservoirs.
- Minimum number of activated sprinklers. Minimum requirements to water flow.

In this picture electrically activated sprinklers are integrated with the optical sensors sensitive to flame radiation. Optical axis of the sensor is directed vertically downwards, and observed area is similar to or larger than the area wetted by the sprinkler in case of activation. To obey this requirement, the view angle is adjusted depending on the sensor elevation. The response of such a system is very fast, being more than an order of magnitude less than that of conventional sprinkler. This system also offers a highly accurate localization of the fire source, which enables precise delivery of the extinguishing agent (water). The latter might be important in heritage sites or in compartments with highly expensive items inside.

## STATIC GROUP ACTIVATION



Second scenario of using sprinklers with electrical activation is a pre-programmed system, when a fire signal from a fire detector activates the sprinklers not only in the area of a fire but on the way of its spread. For example, prevention of flame spread through the doorways and windows in hotels or offices is crucial in high rise buildings.

A proposed technology uses an electrical activation, so there is no necessity to install sprinklers on the ceiling. They can be oriented in such way that will ensure maximum efficiency of the fire extinguishing.

### Advantages:

- guaranteed extinguishing and blocking of fire spread because of a larger sprinkling area;
- usage on highly engineered objects.

In cases when the traditional placement of sprinklers under the ceiling does not provide an effective extinguishing, e. g. when there is no possibility of supplying water to the fire source from the top because of the obstacle: high-rack warehouses or mechanized parking. Having this new activation methodology there is no need to locate sprinklers below the ceiling anymore, they can be installed in such way that will allow maximum quantity of water getting on the fire source.

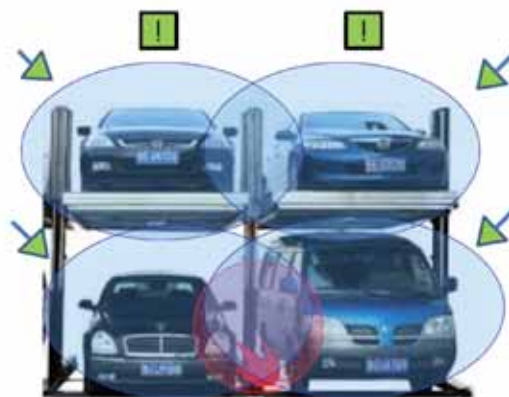

## DYNAMIC GROUP ACTIVATION

Third variant of using sprinklers with electrical activation is a programmed system with dynamic logic, when the group of sprinklers that should be activated is determined by the place of a fire origin. For example, here is the one of possible variants of using such technology. After the first activation of a fire detector, an operator identifies it, and the system defines an adjacent group of sprinklers surrounding the host one. The entire group activates as soon as the bulb is electrically heated (which takes about 10 s).

### Advantages:

- guaranteed extinguishing and blocking of fire spread via larger sprinkling area;
- average requirements to water flow



Another example of this variant is a protection of extended objects, such as transport tunnels or cable collectors. Here activated sprinklers in front and behind of the fire reliably block its spread along the tunnel.

This picture illustrates extinguishing of the fire by the group of simultaneously activated sprinklers, thanks to which the fire is localized rapidly and the damaged area is expected to be much less. Actually we form a deluge section close to the axis of the fire seat. Here the size of the deluge section can be optimized and implemented without any additional pipes and valves by using ordinary sprinkler net.



## “BIPS” CONTROL PANEL

**Implemented type of activation:** individual activation.

Monitoring of one loop with non-addressable detectors/sprinklers. For minimization of a false start possibility “Permission” for activation is used. This “Permission” can be:

- activation of two detectors in a room;
- activation of a manual call point in a loop;
- fire signal from an external control panel;
- pressing start button on BIPS.

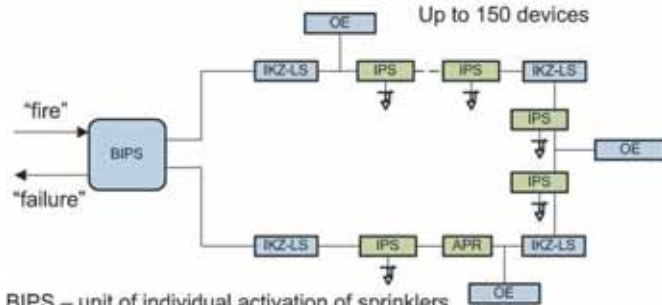

BIPS – unit of individual activation of sprinklers  
 IKZ-LS – isolators of short-circuit  
 OE – terminating element  
 IPS – satellite fire detector  
 APR – manual call point

The loop can have up to 10 branches. A terminating element should be installed at the end of each branch.

Monitoring of circuit of heating elements on discontinuity and short-circuit.

### Advantages:

- low price;
- minimum quantity of activated sprinklers; minimum requirements to water flow

## “BIPS” Technical specification

Type of system	non-addressable
Types of detectors	heat detectors manual call points
Number of loops	1
detectors/sprinklers per loop	150
manual call points per loop	10
short circuit isolators	4
Sprinkler activation current	200 mA

## “GEFEST” CONTROL PANEL

**Implemented type of activation:** static group activation.

Monitoring of one line with non-addressable sprinklers with control of activation. CU does not have own detectors.

The system is consisted of a head unit and expanding modules. The number of expanding modules per one head unit is not limited. Command to activation is a relay output signal from an external control panel. For minimization of a false start possibility two inputs are used. Sprinklers are activated if there are two signals.

Monitoring of the line area before sprinklers on discontinuity and short-circuit.

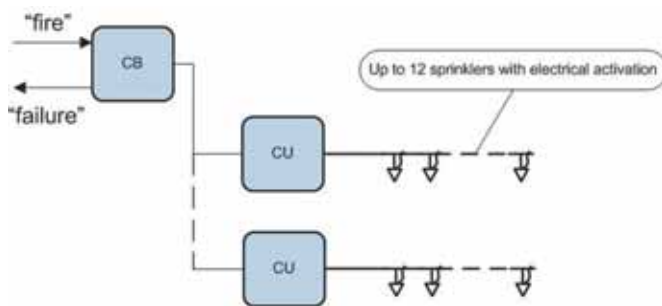

CB – head unit  
 CU – unit of group start of sprinklers

Possibility of integration of several CU into one non-addressable system.

### Advantages:

- low price;
- guaranteed extinguishing and blocking of fire spread because of a larger sprinkling area;
- usage on highly engineered objects.

## “CU” Technical specification

Type of system	non-addressable
Types of detectors	—
Number of sprinklers per expanding device	12
Sprinkler activation current	200 mA

## “OLIMP” CONTROL PANEL

**Implemented type of activation:** individual activation, group activation – dynamic and static.



A special system was implemented to control addressable fire detectors and sprinklers with electrical activation. Its structure is designed to reduce amount of electric wires to the minimum possible value. This is achieved by grouping to one loop addressable satellite detectors combined with sprinklers connected to the line controller. Operation via local controllers KL (240 addresses per local controller). Total amount of sprinklers which could be managed by the system is 4800. Current status of the system operation is displayed on the operator’s console.

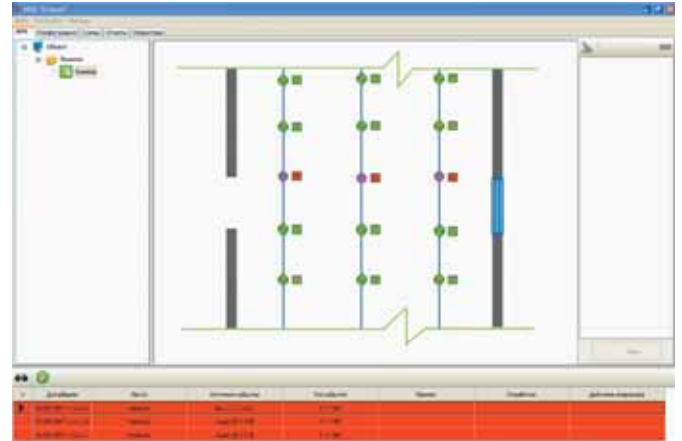

Operator’s console offers an opportunity of independent control of each sprinkler, includes user guide and list of expected fire scenarios. The operator’s console makes it possible to activate manually any sprinkler.

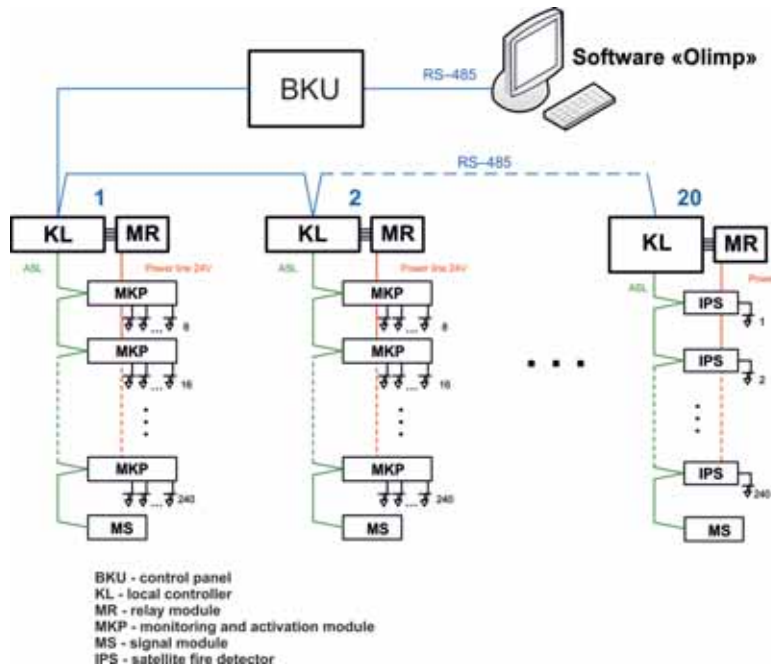

### “Olimp” Technical specification

Type of system	addressable
Types of detectors	heat detectors, flame detectors, combined detectors (heat & flame)
Number of detectors/sprinklers per local controller	240
detectors/sprinklers per system	4800
local controllers per system	20
Sprinkler activation current	200 mA

The new draft for a new part of the International Standard 6182 has been developed. The relevant draft was presented to your attention. It proposed definitions, specific requirements and test methods for new sprinklers. Obviously, functions of forced start and control of the sprinkler could be realized not only by methods discussed above. There was a voting among members of TC21/SC5 and this draft was approved on August 11, 2016. Further work will be discussed at the ongoing ISO meeting in Norwood.



NEW WORK ITEM PROPOSAL		
Date of presentation 8-9-2015	Reference number (to be given by the Secretariat)	
Proposer GOST	ISO/TC 21 / SC 5	<b>N 766</b>
Secretariat ANSI		

**Proposal** (to be completed by the proposer)

<b>Title of proposal</b> (in the case of an amendment, revision or a new part of an existing document, show the reference number and current title)	
English title	Fire protection — Automatic sprinkler systems — Part 15: Sprinklers with electrical activation and monitoring of activation
French title (if available)	
<b>Scope of proposed project</b>	
This proposal is designing of the new part in a current document ISO 6182: the part 15 - Sprinklers with electrical activation and monitoring of activation	

The uniqueness of electrically controlled sprinklers is proved by numerous awards and confirmed by Russian and international patents.



## About us

“Gefest” Enterprise Group was founded in 1999 and nowadays it is one of the leading Russian companies in the area of fire safety. For the years of its work the company has developed into a strong and stable enterprise with more than 200 workers. Basic activity directions of “Gefest” Enterprise Group are manufacturing of fire protection equipment, design and installation of fire safety systems. Wide range of activity types of the company allows integrating effective fire safety systems on the basis of own unique devices.



CEO of “Gefest” Enterprise group Leonid Tanklevskiy

Scientific and engineering potential of the enterprise is formed by the staff of highly skilled technical and research workers. Scientific research works are resulted into the production, which uniqueness is proved by numerous awards and confirmed by Russian and international patents. Requirements to the designed production have been included into the Russian standards and nowadays are discussed at the ISO/TC21 committee «Equipment for fire protection and fire fighting». High production standards and the production quality are proved by the certificate ISO 9001:2011.



65A Serdobolskaya str.,  
St.Petersburg, Russia  
Zip code: 197342

Phone: +7 (812) 600-69-11  
e-mail: [office@gefest-spb.ru](mailto:office@gefest-spb.ru)  
[www.gefest-spb.ru](http://www.gefest-spb.ru)