

School Lockdown Procedures & Systems

As a result of the escalating threat of firearms, weapons and terrorist attacks on schools, a Dynamic Lockdown Procedure provides an effective strategy to rapidly restrict access to the premises.

What a Dynamic Lockdown procedure is

A Dynamic Lockdown Procedure provides an effective plan to quickly restrict access to and movement throughout a building (or area within a building) through actions and physical measures in response to an imminent threat.

What to consider in planning a Lockdown procedure

- How to achieve effective full or partial lockdown of the environment / building
- How to communicate with students, staff, colleagues as to what is happening in the initial stages and during any attack
- Training staff on the procedure

How to develop a Dynamic Lockdown Procedure

- Identify clear communication options to all staff
- Identify how to quickly secure all access points (using locks, access control systems, door bars or furniture, for example)
- Identify how your site can be split into zones to allow specific areas to be locked down (as opposed to just the entire site)
- Ensure clear roles and responsibilities for all staff form part of your Procedure
- Effective staff training on your procedure should regularly be delivered to all staff
- Stopping people entering or leaving the site and directing people away from the danger
- Procedures should be flexible enough to deal with the unknown and fast-changing situations
- As part of the planning of your individual Lockdown Procedure, you should identify all access and egress points in the public and private areas of your building or campus. Remember that access points may be more than just doors and gates (such as windows, roof lights, etc)

What a School Lockdown System is

Understanding the distinction between a Lockdown Procedure and a Lockdown System - and how the two should be combined - is key to providing the most effective and cohesive overall solution. Whereas a Lockdown Procedure focusses on establishing a defined series of actions, a Lockdown System can employ a wide variety of resources and technologies to greatly improve the communication and access control measures. The fundamental components of a Lockdown System can be categorised into two main groups - Communication & Access Control...

COMMUNICATION

...to provide the most effective, clear communication to staff, students, visitors, etc both at the instigation and throughout a Lockdown Procedure.

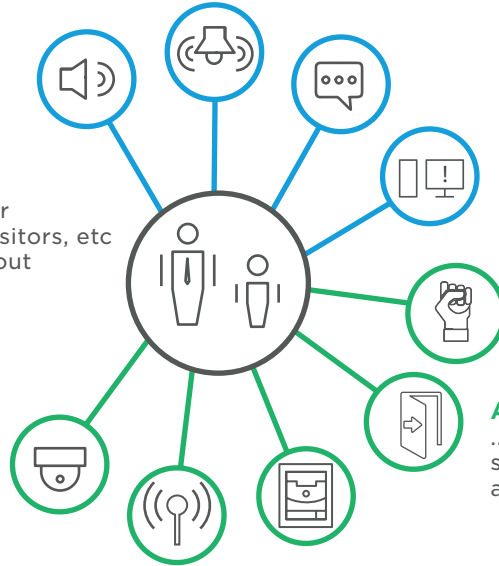

ACCESS CONTROL

...to provide the most secure environment for staff, students & visitors and to inhibit the access / egress of any attackers.



Public Address/Audio Systems - including 100v line, EN54 & IP audio



Bell Timing Systems



Personal Messaging Systems such as text, email or pop-up notifications



Visual Warning Systems such as digital signage, dot matrix displays or beacons



Automatic Activation Systems such as electric doors, access control or mag. lock systems



Door Monitoring Systems



Video Door Entry Systems



Wireless Distress Systems such as personal distress call devices



CCTV and Surveillance Systems

A Lockdown tailored to your needs

Our team of expert system designers work in partnership with professional security and AV installers to design and deliver a high quality Lockdown System based on the needs of your school, your individual Lockdown Procedure, as well as any additional increased risk factors.

Each Lockdown System we supply is based on a detailed site survey of your school/campus, during which we will consider any existing communication / security systems and resources already in place which could be utilised as part of the system.

Our solutions are entirely scalable, based on size of school, individual Lockdown Procedure, risk factors and budget and will draw from the full range of technologies available to achieve the most effective and cohesive solution to meet your needs.

SYSTEM DESIGN SUPPORT FOR YOUR LOCKDOWN SYSTEM

2N is a leading company engaged in the development and manufacture of products in the field of Communications and physical security. Our team of system designers provide a specification & design service to help you develop the best Lockdown System for your environment using existing or new infrastructure.

Our team will help to specify a Dynamic Lockdown System tailored to meet the individual needs of your school, college, university or business premises. Based on size of school, individual Lockdown Procedure, risk factors and budget and will draw from the full range of technologies available to achieve the most effective and cohesive solution to meet your needs.

For more information about possible scenarios and product specification contact your Account Manager or presales@2n.cz.

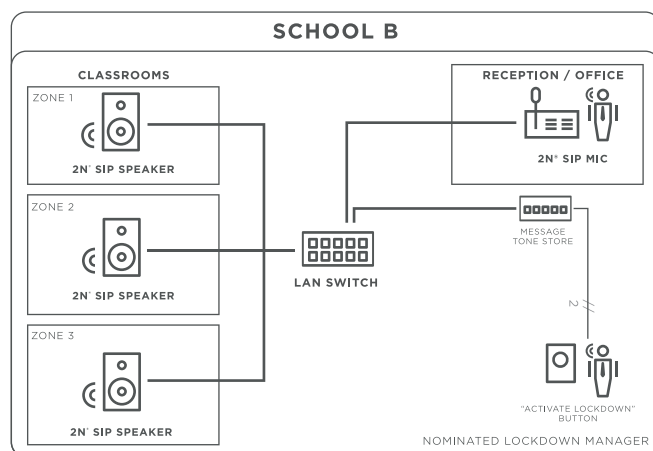
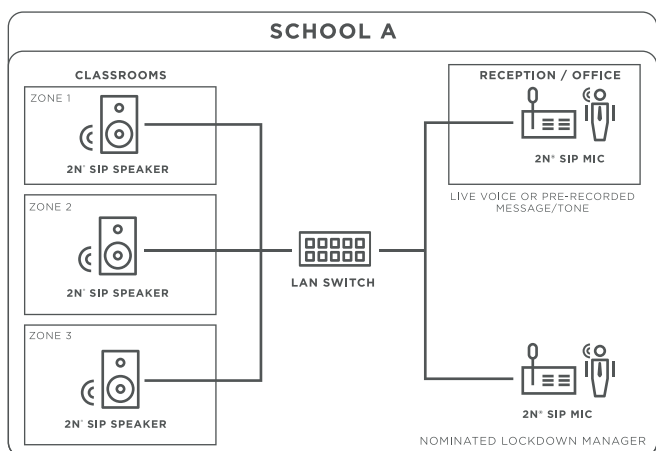

PUBLIC ADDRESS SYSTEM

A standard distributed IP based audio (public address) system is perhaps the simplest solution to provide school-wide clear communication to all staff, students, visitors, etc.

It allows for immediate warning of Lockdown Procedure being engaged and for updates throughout the school as any situation reaches resolution.

'ONE-BUTTON' TRIGGERED AUDIO SYSTEM

This example shows a Lockdown System and School Bell Timing System combined.

The Bell Timing System allows for pre-set bell or tones for class-change notification, as well as providing an alternative alarm, message or tone to warn of Lockdown Procedure being engaged.

This example features both microphone and 'One-button' Lockdown trigger, allowing for the Lockdown 'alarm' to be set-off using alternative sources.

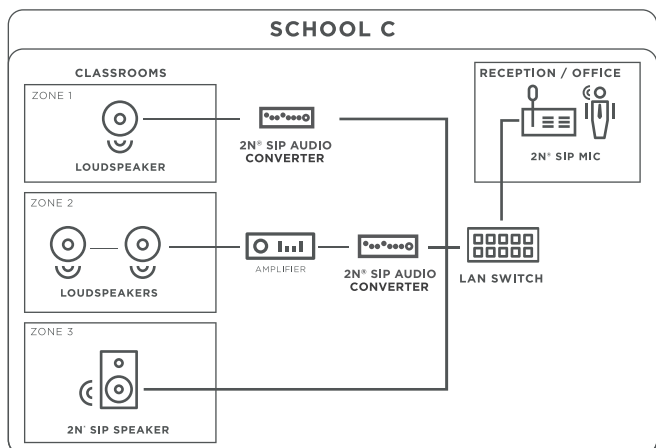

'HYBRID' NETWORK AUDIO SYSTEM

This 'hybrid' audio system example utilises both standard 100V line audio together with the latest network audio technology.

Such a system is often used to combine existing public address infrastructure with network building management systems.

SCHOOL LOCKDOWN PROCEDURES & SYSTEMS

FULLY INTEGRATED DYNAMIC SCHOOL LOCKDOWN SYSTEM

The following example combines communication and access control devices over a standard network infrastructure, to provide a fully integrated Dynamic School Lockdown System.

Featuring a combination of 100V line & network audio, door entry & intercom, standard IP telephone systems and CCTV, this example of an integrated Lockdown System not only offers multiple-layer Lockdown functionality, but can also be used for additional operations including class-change, door entry/access control, messaging and much more.

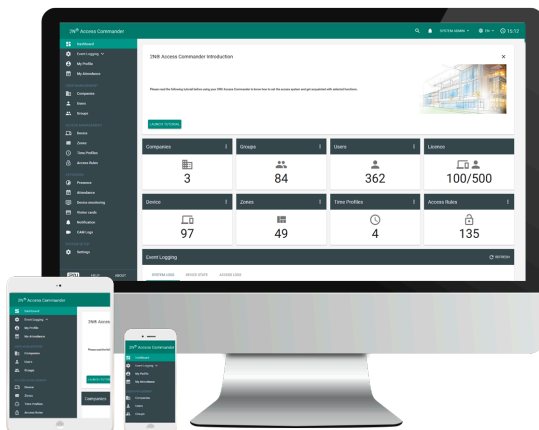
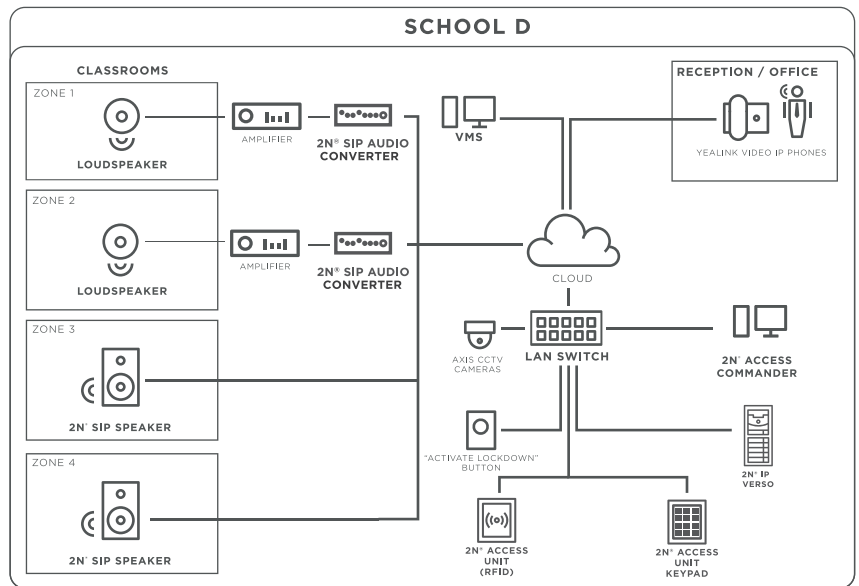

2N® ACCESS COMMANDER

The nerve centre of the whole Lockdown System is 2N® Access Commander with its simple and intuitive user interface. Use it not only for managing access to the building, but also for monitoring the status of access units in real time.

2N Telekomunikace a.s.

2N is a leading company engaged in the development and manufacture of products in the field of Communications and physical security. We are #1 in the IP intercom market, complying with the most stringent international standards (ISO, TÜV, UL, CE). Our products are compatible with third party systems (Genetec, Milestone, Cisco, Bosch, Avaya, Alcatel-Lucent and many more).

We are continually expanding our operation and currently do business with partners in more than 125 countries. You will find our branches all over the world. We are a part of AXIS group.

For more information about possible scenarios and product specification contact your Account Manager or

PRESALES@2N.CZ